

Operating instructions for PM laser diode module

General operating instructions

Introduction

The PM is a rugged laser module with a variety of options and accessories. This product can be configured with a variety of laser diodes at various output powers and operating wavelengths. Products with IR output or with more than 5mW of output power are not intended for surveying, leveling, and alignment applications. Visible units with less than 5mW of output power are CDRH certified as laser systems.

The module operates in constant optical output power mode only. This means that if there is a change in temperature, focus, or any other dynamic that changes the output of the laser, the power supply will automatically adjust current output to compensate. This maintains a constant and stable output power.

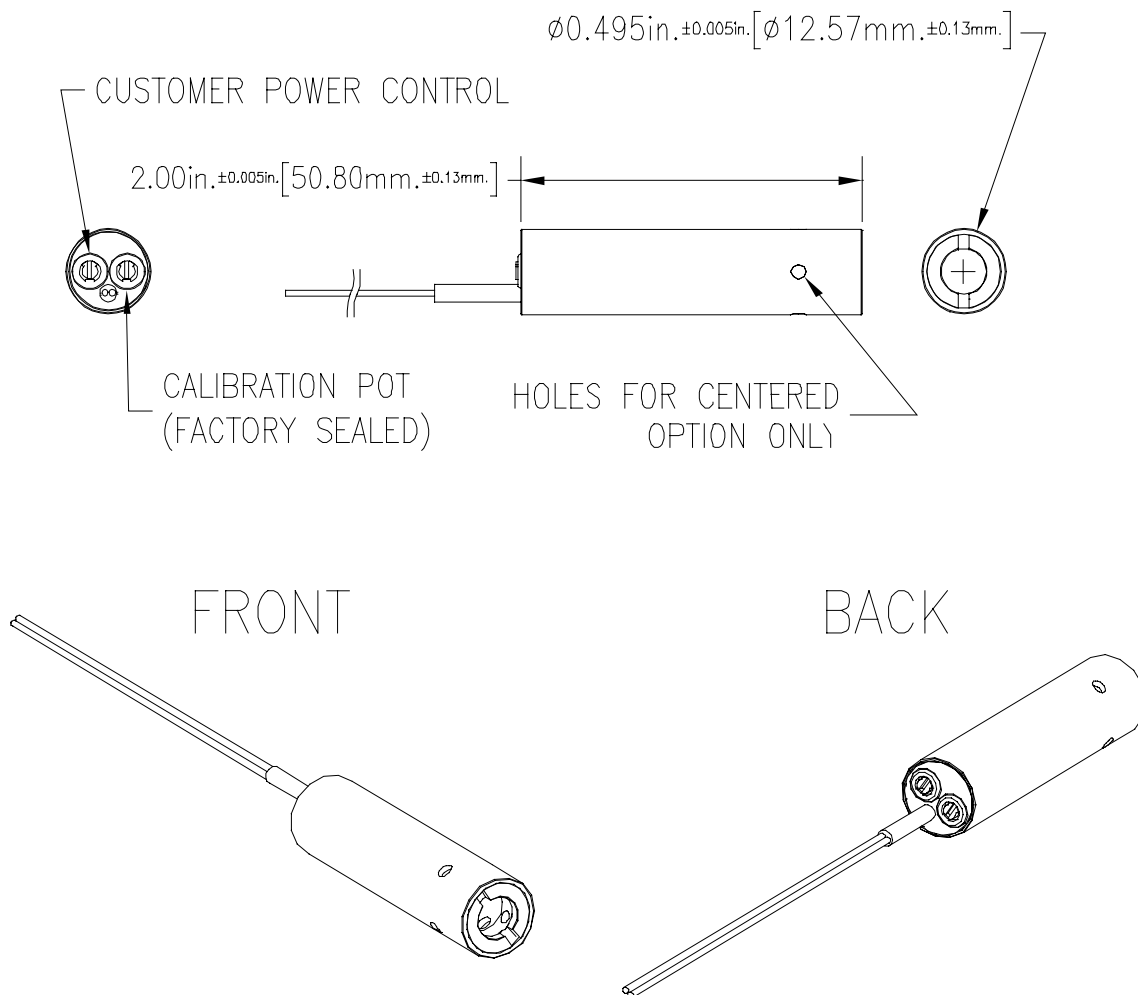

Installation

Do not mount the laser in a thermal insulating material, such as foam plastic. Heat can have adverse effect on laser diodes including decreased output power and large shifts in wavelengths. The lifetime of the laser can also be shortened. Lasers below 5mW may not need a heat sink. For best heat dissipation, use a metal mounting fixture. If the system is to be run at or near the maximum rated input voltage, the use of a heat sink is recommended. A heat sink is always recommended for operating temperatures above 25°C. Mounting brackets are available for PM laser modules. Simply ask your salesperson for more information.



The operating voltage for this laser module is from 3.3 VDC to 9 VDC. Positive power should be applied to the module's red wire, and the black wire should be connected to ground.

If the label attached to the laser module reads "This product complies with 21CFR 1040.10 and 1040.11, IEC60825-1 AM2:2001," a permanently installed switch at the power source will be required to retain the module's certification as a laser system. This certification is void if the unit is enclosed, or otherwise inaccessible, if the labels are modified or removed, or the system is permanently connected (i.e. soldered, etc.) directly to the power source without the required switch. Modifying the laser will void the CDRH certification. If the distance between the laser head and the power source switch exceeds two meters, an emissions indicator must be mounted near the switch.

Operating Procedures & Control Description

The PM laser module features two user adjustments. The optical output power can be adjusted from zero up to 100% via the Customer Power Control potentiometer located on the rear of the unit. When looking at the rear of the laser module, rotate the module until the wire is on the bottom. The potentiometer located on the left is the Customer Power Control potentiometer. Turning this potentiometer clockwise will increase the power. Turning the potentiometer counter-clockwise will decrease the power. It is not possible to overdrive the diode using this potentiometer. The potentiometer on the right is for factory calibration and is sealed to prevent usage. Breaking this seal will void the warranty. The laser can be focused to a spot at various distances using the spanner wrench included with the unit. Care should be taken when focusing or cleaning the optics to prevent damage.

Reflections onto the internal photodiode from the lens are a vital part of the feedback loop. This photodiode is very sensitive to these reflections. Any adjustment of the lens outside the normal focusing range (beam divergence to beam convergence) will change the amount of reflections, thereby changing feedback characteristics. Therefore, adjusting the focus with the module at full power will destroy the laser diode. Also, reducing the amount of reflections (i.e., removing the lens) may result in destruction of the laser diode due to excessive drive current.

Maintenance & Service

This laser module contains no user serviceable parts. Depending on environmental conditions, the optics may require occasional cleaning. Use of clean, compressed air is recommended to blow the optics clean. If compressed air fails, clean lens carefully with PGA alcohol or high purity acetone and a lint free rag or cotton swab.

Warranty and Repair Return Policy

For systems that incorporate a centering option, adjustment of the centering setscrews will void the diode warranty and possibly the warranty on the entire laser system since damage to the diode is easily achievable.

No return of merchandise will be accepted by PTI without an RMA (Return Material Authorization) number, issued by the factory and prominently displayed on the return package.

No return shipments will be accepted "Collect" or "COD". On warranty returns, PTI will pay for shipping charges on return of merchandise to the customer.

When contacting the factory for an RMA number, please have the following information available: model number, serial number, and a description of the problem.

Laser Safety

Caution: Use of controls or adjustments or performance of procedures other than those specified herein may result in hazardous radiation exposure.







Caution: The use of optical instruments with this product will increase eye hazard.







Do not shine laser in the direction of other people or at reflective surfaces that might cause exposure to the human eye. Do not mount the laser at eye level.



Modifications that affect any aspect of the product's performance or intended functions will require re-certification and re-identification of the product in accordance with the provisions of 21CFR 1040.10 and 1040.11. A copy of 21CFR 1040.10 and 1040.11 can be downloaded from www.powertechnology.com.

The product labels shown below can typically be found near the output optics.

<p align="center">Class 1 Laser: Class 1 Laser Product</p> <p><input type="checkbox"/> Component</p>  <p><input type="checkbox"/> System</p>  <p align="center">One of the above labels is attached to the laser head.</p>	<p align="center">Class 1M Laser: Laser Radiation, Do not view directly with optical instruments</p> <p><input type="checkbox"/> Component</p>  <p><input type="checkbox"/> System</p>  <p align="center">One of the above labels is attached to the laser head.</p>	<p align="center">Class 2 Laser: Laser Radiation, Do not stare into beam</p> <p><input type="checkbox"/> Component</p>  <p><input type="checkbox"/> System</p>  <p align="center">One of the above labels is attached to the laser head.</p>
---	---	---

<p align="center">Class 2M Laser: Laser Radiation, Do not stare into the beam or view directly with optical instruments</p> <p><input type="checkbox"/> Component</p>  <p><input type="checkbox"/> System</p>  <p align="center">One of the above labels is attached to the laser head.</p>	<p align="center">Class 3R Laser: Laser Radiation, Avoid direct eye exposure</p> <p><input type="checkbox"/> Component</p>  <p><input type="checkbox"/> System</p>  <p align="center">One of the above labels is attached to the laser head.</p>	<p align="center">Class 3B Laser: Laser Radiation, Avoid exposure to beam</p> <p><input type="checkbox"/> Component</p>  <p><input type="checkbox"/> System</p>  <p align="center">One of the above labels is attached to the laser head.</p>
--	---	--

