

Operating instruction for PPMT with D2 option

PPMT laser diode module with drive current digital control option

The latest version of this document can be found on our website at www.powertechnology.com.

Introduction

The PPMT laser diode module is designed for external TTL compatible modulation from CW up to 20MHz. The module features active temperature control via a built-in Peltier Junction and fan.

These instructions are specifically intended to explain the operation of the PPMT's digital control option only. For a detailed description of the module's operation and functions, see operating instruction OI_PPMT.

The drive current digital control option (option D2) is a digital interface between the laser diode drive circuit and a user-supplied controller. This interface replaces the standard mechanical potentiometer used to adjust drive current to the laser diode. Using this interface, the module is not only digitally controllable, but it is also TTL compatible.

The D2 option allows the operator to precisely calibrate the drive current, store a setting in the unit's memory, and retain this setting for future use. This added control greatly improves the stability of the unit, preventing someone from easily adjusting a manual potentiometer and changing the laser output. In this manner, the module can more easily maintain compliance with CDRH regulations, and there will be no need to physically handle the module and risk accidental misalignment.

The D2 option also enhances safety and reliability. By eliminating easy access to the current adjustment, the laser is protected from inadvertent excessive current adjustment and laser burnout. Also, the module can be preset to start up at low or no laser output, regardless of what adjustments were made before the previous shutdown. This feature reduces safety hazards, prevents overshoot of the drive current, and helps to extend lifetime for the laser diode.

Installation

Do not mount the laser in a thermal insulating material, such as foam plastic. Heat can have adverse effects on laser diodes. Such effects include decreased output power and large shifts in wavelengths. Lasers below 5mW may not need a heat sink. For best heat dissipation, use a metal mounting fixture such as PTI's MB6 mounting bracket. A heat sink is always recommended for operating temperatures above 25°C.

If the label attached to the laser module reads "Complies with 21CFR 1040.10 and 1040.11," a permanently installed switch at the power source will be required to retain the module's certification as a laser system. This certification is void if the unit is enclosed or otherwise inaccessible, if the labels are modified or removed, or if the system is permanently connected (i.e. soldered, etc.) directly to the power source without the required switch. Modifying the laser will void the CDRH certification. If the distance between the laser head and the power source switch exceeds two meters, an emissions indicator must be mounted near the switch.

Operating Procedure & Control Description

The D2 option features a solid-state nonvolatile potentiometer. The potentiometer is a resistor array composed of 99 resistive elements. Between each element and at either end are tap points accessible to the wiper element, giving 100 possible resistance settings. The position and movement direction of the wiper element is controlled by pulsed inputs through the three wire leads exiting the system, one step for each pulse. The position of the wiper can be stored in the system's nonvolatile memory and then be recalled upon a subsequent power-on operation.

When the system is powered down, the last resistance position *stored* will be maintained. When the power is restored, the contents of the memory are recalled, and the system is reset to the value last stored. The operator may change the resistance setting without having to store the latest position in memory. Adjustments might be based, for instance, on user preference or on system parameter changes due to temperature drift. The new setting would be maintained until changed by the operator or until a power off/on cycle recalled the previously stored setting.



Mailing: P. O. Box 191117, Little Rock, AR 72219-1117 • Shipping: 16302 Alexander Road, Alexander, AR 72002
Tel: 501.407.0712 • Fax: 501.407.0036 • Email: sales@powertechnology.com • Web: www.powertechnology.com

Copyright 2005 Power Technology Inc.

Fig. 1 Optical Power vs. Forward Current

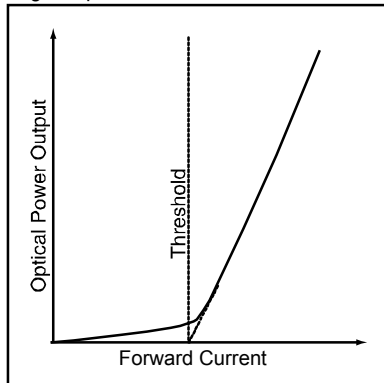

Fig. 1: Although the resolution of the potentiometer is linear and each step can, therefore, be calculated, the laser diode is nonlinear, and each has its own distinct threshold current (the point at which the laser begins to produce output). Therefore, the operator will have to send a number of pulses, if beginning from zero, before the unit will begin to lase.

Lead Configuration

The three input wires that comprise the interface are as follows.

- Chip Select (**\overline{CS}**) The Digital Control option is selected when the (\overline{CS}) input is low (or connected to ground). The current counter value is stored in nonvolatile memory when (\overline{CS}) is returned high (or ungrounded) while the (\overline{INC}) input is also high (or ungrounded). After the store operation is complete, the Digital Control will be placed in the low power standby mode until it is selected once again.
- Increment (**\overline{INC}**) The (\overline{INC}) input is negative-edge triggered. Toggling (\overline{INC}) will move the wiper one step for each toggle, and either increment or decrement the counter in the direction indicated by the logic level on the (U/\overline{D}) input.
- Up/Down (**U/\overline{D}**) The (U/\overline{D}) input controls the direction of the wiper movement and whether the counter is incremented or decremented. When the (U/\overline{D}) input is low (or connected to ground) the wiper movement will be down. When the (U/\overline{D}) input is high (or ungrounded) the wiper movement will be up.

Fig. 2: The diagram not only shows the lead identification but also illustrates a possible TTL hookup. **The interface requires 5VDC as the high logic state.** An internal regulator provides this voltage. The larger red/black leads (22 ga.) are the 12V inputs.

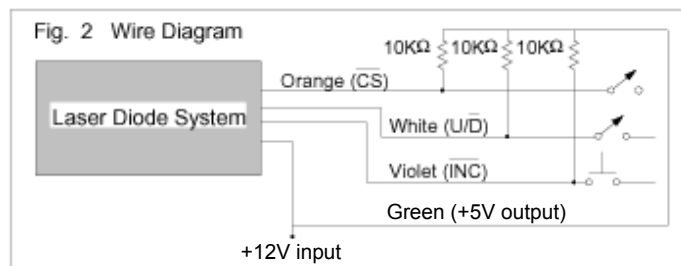

Fig. 3 Connector/Pin Identification

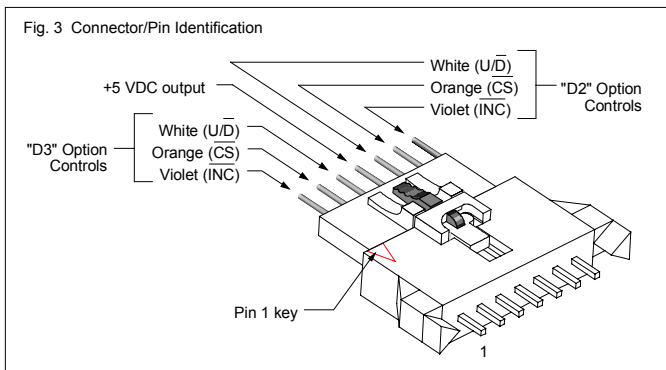

Fig. 3: Each digital control option has the same three wires/controls. Fig. 3 illustrates the proper wire group for each control. From the factory, the connector has a shorting wire soldered across the 7 pins, which enables users to operate the system immediately upon receipt without additional wiring. The unit will turn on to the factory-stored settings. The shorting wire should be removed, and the control wires should be connected (as in Fig. 2) to make adjustments.



To illustrate the digital control operating procedure, we will use the example TTL hookup described in Fig. 2 on the preceding page.

- Select the control:** To operate the control or make any adjustments, the switch on the orange (\overline{CS}) lead must be closed. Open it to deselect the control (as outlined below) and to prevent further adjustments.
- Select direction:** Using the switch on the white (U/\overline{D}) lead, select the direction of the adjustment you want to make.
- Current adjustment:** Repeated closure, or toggling open/closed, of the momentary push button switch on the violet (\overline{INC}) lead will change the drive current in one increment for each toggle. The drive current will either increase or decrease depending on the setting of the switch on the white (U/\overline{D}) lead.
- Storing in memory:** To store the drive current setting in memory, deselect the control by opening the switch on the orange (\overline{CS}) lead while the (\overline{INC}) button is not depressed. The combination of these two switches being open saves the drive current setting to memory. If you do not want to store the drive current setting in memory, or if you want to retain the previous memory setting, hold down the momentary push button switch (\overline{INC}) while you open the (\overline{CS}) switch, thus deselecting the control.

Maintenance & Service

This laser module contains no user serviceable parts. Depending on environmental conditions, the optics may require occasional cleaning. The use of clean, compressed air is recommended to blow the optics clean. If compressed air fails, clean lens carefully with alcohol and a lint free rag or cotton swab.

Warranty and Repair Return Policy

No return of merchandise will be accepted by PTI without an RMA (Return Material Authorization) number, issued by the factory and prominently displayed on the return package.

No return shipments will be accepted "Collect" or "COD". On warranty returns, PTI will pay for shipping charges on the return of merchandise to the customer.

When contacting the factory for an RMA number, please have the following information available: model number, serial number(s), and a description of the problem.

Laser Safety

Class 3b and 4 lasers are not intended for use in surveying, leveling, alignment, or medical applications.

Caution: Use of controls or adjustments or performance of procedures other than those specified herein may result in hazardous radiation exposure.













Caution: The use of optical instruments with this product will increase eye hazard.

Do not shine laser in the direction of other people or at reflective surfaces that might cause exposure to the human eye. Do not mount the laser at eye level.

Modifications that affect any aspect of the product's performance or intended functions will require re-certification and re-identification of the product in accordance with the provisions of 21CFR 1040.10 and 1040.11. A copy of 21CFR 1040.10 and 1040.11 can be downloaded from www.powertechnology.com.



The product labels shown below can typically be found near the output optics.

<p align="center">Class 1 Laser: Class 1 Laser Product</p> <p><input type="checkbox"/> Component</p>  <p><input type="checkbox"/> System</p>  <p align="center">One of the above labels is attached to the laser head.</p>	<p align="center">Class 1M Laser: Laser Radiation, Do not view directly with optical instruments</p> <p><input type="checkbox"/> Component</p>  <p><input type="checkbox"/> System</p>  <p align="center">One of the above labels is attached to the laser head.</p>	<p align="center">Class 2 Laser: Laser Radiation, Do not stare into beam</p> <p><input type="checkbox"/> Component</p>  <p><input type="checkbox"/> System</p>  <p align="center">One of the above labels is attached to the laser head.</p>
<p align="center">Class 2M Laser: Laser Radiation, Do not stare into the beam or view directly with optical instruments</p> <p><input type="checkbox"/> Component</p>  <p><input type="checkbox"/> System</p>  <p align="center">One of the above labels is attached to the laser head.</p>	<p align="center">Class 3R Laser: Laser Radiation, Avoid direct eye exposure</p> <p><input type="checkbox"/> Component</p>  <p><input type="checkbox"/> System</p>  <p align="center">One of the above labels is attached to the laser head.</p>	<p align="center">Class 3B Laser: Laser Radiation, Avoid exposure to beam</p> <p><input type="checkbox"/> Component</p>  <p><input type="checkbox"/> System</p>  <p align="center">One of the above labels is attached to the laser head.</p>



Class 4 Laser:

Laser radiation, Avoid eye or skin exposure to direct or scattered radiation

Component



System



One of the above labels is attached to the laser head.

