



Long Coherence Length Laser

Instrument quality performance
for high-end OEM applications.



The Instrument Quality IQ6 laser diode module has been created specifically to address the needs of high-end OEM applications requiring narrow spectral widths and long coherence lengths.

With wavelengths ranging from 390 to 2320nm, the IQ6 features a spectral width of < 5 MHz, and provides coherence lengths of over 15 meters.

The IQ6 laser features a precision current source and a PID temperature control loop that allows the unit to create less excess heat within the laser module, increasing diode lifetime, efficiency and reliability.





Features

- PID temperature control loop & precision current source
- CW, analog modulation, or digital beam modulation
- Circularized collimated beam

Applications

- Holography
- Interferometry
- Bioanalysis
- Fluorescence
- Raman spectroscopy

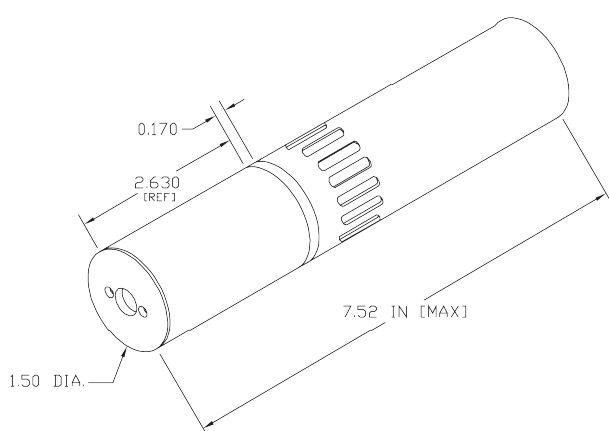

Specifications	IQ6
Operation Mode	CW, single (fixed) frequency
Wavelength	405nm
Wavelength tolerance	± 0.2 nm
Wavelength stability	< 20 pm/h (peak to peak)
Spectral Width	< 5 MHz single (fixed) frequency
Coherence length	> 15 m
ASE suppression (380nm - 1600nm)	40dB typ.
Optical power (free-space)	50 mW
Power stability	Typ. < 0.5 %
Intensity noise (RMS)	≤ 0.1% @ 10 Hz – 10 MHz
Polarization	Linear, > 100 : 1, vertical (free-space version)
Beam shape	Circular collimated-beam
Spatial mode	M ² < 1.2
Optical isolation	Not included
Warm-up time	< 10 min
Operating voltage	5-13 VDC
Maximum operating current	(mA) 3000
Beam size	~ 1.0 mm
Beam divergence	(mrad) < 1.0

Other available wavelengths

Wavelength (nm)	Power (mW)	Spectral Width
390-400	16	< 5 MHz
400-410	36	< 5 MHz
410-415	36	< 5 MHz
414-420	36	< 5 MHz
450-455	24	< 5 MHz
650-655	32	< 5 MHz
730-740	16	< 5 MHz
760-790	146	< 5 MHz
750-790	80	< 5 MHz
780-810	146	< 5 MHz
780-850	80	< 5 MHz
830-870	80	< 5 MHz
810-880	80	< 5 MHz
900-1000	96	< 5 MHz
960-1080	56	< 5 MHz
1020-1090	320	< 5 MHz
1010-1110	160	< 5 MHz
1035-1115	200	< 5 MHz
1100-1128	200	< 5 MHz
1141-1171	160	< 5 MHz
1153-1200	160	< 5 MHz
1130-1230	160	< 5 MHz
1155-1285	80	< 5 MHz
1240-1280	120	< 5 MHz
1403-1497	16	< 5 MHz
1520-1580	48	< 5 MHz
1540-1640	48	< 5 MHz
1605-1695	2.8	< 5 MHz
2070-2110	24	< 5 MHz
2130-2170	24	< 5 MHz
2280-2320	24	< 5 MHz

