

TAPERED AMPLIFIER

GaAs Semiconductor Laser Diode



PRELIMINARY SPECIFICATION

Tapered Amplifier

EYP-TPA-0808-01000-4006-CMT04-0000**General Product Information**

Product	Application
808 nm Tapered Amplifier	Spectroscopy
C-Mount Package	Metrology

**Absolute Maximum Ratings**

	Symbol	Unit	min	typ	max
Storage Temperature	T_S	°C	-40		85
Operational Temperature at Case	T_C	°C	0		50
Current	I_F	A			3
Reverse Voltage	V_R	V			0
Output Power	P_{opt}	W			1.1

non condensing

non condensing

Stress in excess of the Absolute Maximum Ratings can cause permanent damage to the device. Operation at the Absolute Maximum Rating for extended periods of time can adversely affect the device reliability and may lead to reduced operational life.

Recommended Operational Conditions

	Symbol	Unit	min	typ	max
Operational Temperature at Case	T_C	°C	5		40
Forward Current	$I_{F\text{ Gain}}$	A			2.5
Input Power	P_{input}	mW	10		50
Output Power	P_{opt}	W			1.0

non condensing

with proper injection from a seed laser

Characteristics at T_{amb} 25 °C at Begin Of Life

Parameter	Symbol	Unit	min	typ	max
Center Wavelength	λ_C	nm		808	
Gain Width (FWHM)	$\Delta\lambda$	nm		15	
Temperature Coefficient of Wavelength	$d\lambda / dT$	nm / K		0.3	
Amplification		dB		13	
Operational Current @ $P_{opt} = 1\text{ W}$	$I_{op\text{ Gain}}$	A			2.5

Measurement Conditions / Comments

with proper injection from a seed laser

TAPERED AMPLIFIER

GaAs Semiconductor Laser Diode



PRELIMINARY SPECIFICATION

Tapered Amplifier

EYP-TPA-0808-01000-4006-CMT04-0000**Characteristics at T_{amb} 25 °C at Begin Of Life**

Parameter	Symbol	Unit	min	typ	max
Output Power @ $I_f = 2.5$ A	P_{opt}	W	1		
Cavity Length	L	μm		4000	
Input Aperture (at rear side)	d_{input}	μm		3	
Output Aperture (at front side)	d_{output}	μm		290	
Astigmatism	A	μm			600
Divergence parallel (FWHM)	$\Theta_{ }$	$^\circ$		15	
Divergence perpendicular (FWHM)	Θ_{\perp}	$^\circ$		28	
Polarization				TM	

Measurement Conditions / Comments

with proper injection from a seed laser

depending on operating conditions

E field perpendicular to junction plane

TAPERED AMPLIFIER
GaAs Semiconductor Laser Diode



PRELIMINARY SPECIFICATION

Tapered Amplifier

EYP-TPA-0808-01000-4006-CMT04-0000

Package Dimensions

	Symbol	Unit	min	typ	max
Emission Plane	l	mm	7.05	7.20	7.35
C-Mount Thickness	d	mm		4.15	

Package Pinout

Cathode (-)	Mounting Wire
Anode (+)	Housing

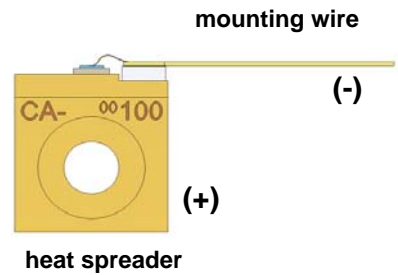

Package Drawings

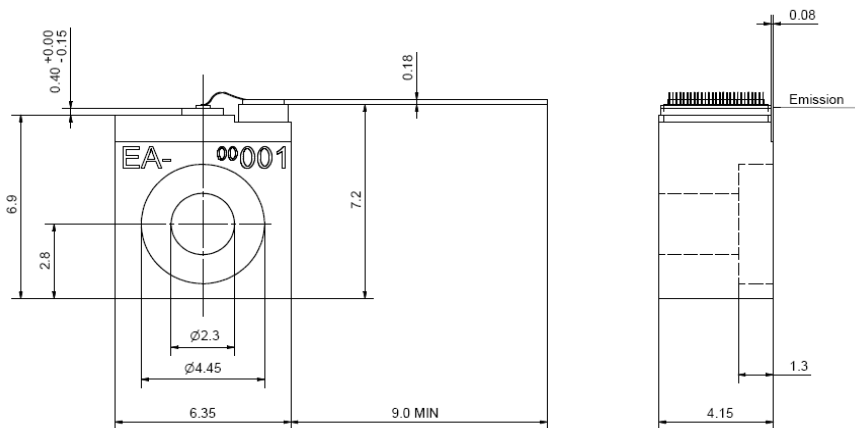

TAPERED AMPLIFIER

GaAs Semiconductor Laser Diode



PRELIMINARY SPECIFICATION

Tapered Amplifier

EYP-TPA-0808-01000-4006-CMT04-0000

Typical Measurement Results

Spectrum measured w/o injection

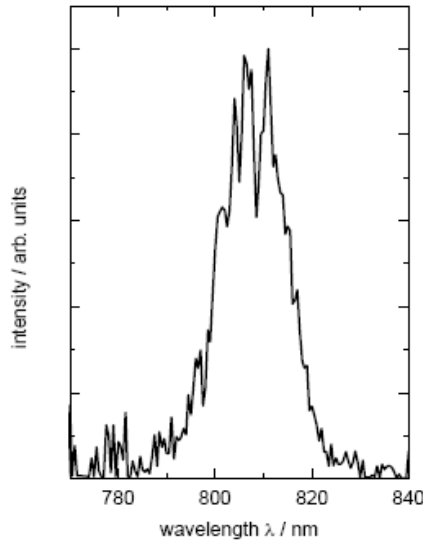

Performance figures, data and any illustrative material provided in this specification are typical and must be specifically confirmed in writing by eagleyard Photonics before they become applicable to any particular order or contract. In accordance with the eagleyard Photonics policy of continuous improvement specifications may change without notice.

Unpacking, Installation and Laser Safety

Unpacking the laser diodes should only be done at electrostatic safe workstations (EPA). Though protection against electro static discharge (ESD) is implemented in the laser package, charges may occur at surfaces. Please store this product in its original package at a dry, clean place until final use. During device installation, ESD protection has to be maintained.

The TPA diode type is known to be sensitive against thermal stress. It should not be operated without appropriate injection from a seed laser. Operating at moderate temperatures on proper heat sinks will contribute to a long lifetime of the diode.

The laser emission from this diode is close to the invisible infrared region of the electromagnetic spectrum. Avoid direct and/or indirect exposure to the free running beam. Collimating the free running beam with optics as common in optical instruments will increase threat to the human eye.

Each laser diode will come with an individual test protocol verifying the parameters given in this document.

