



HeNe Laser Power Supply Instructions A\C Input (Models SL45, L88, L92, SL92, SL93)

Since 1969, Power Technology, Inc. has manufactured HeNe Laser Power Supplies for the scientific and industrial markets. The information provided below will help you install and operate these products. If you have any questions, please call one of our Sales Engineers at 1-501-407-0712 or E-mail sales@powertechnology.com.

Mounting

Depending on the power supply, two or three 0.157" (4mm) diameter holes are provided for mounting purposes. Please mount the power supply to a flat surface using a number 6 (US) or M2 (metric) screw. Please use a flat washer under the head of the screw. This will spread the pressure and prevent cracking of the case. **Caution:** Do not over-tighten these screws. Cracked cases are not covered under warranty.

Mount the power supply to a surface that will conduct heat away from the power supply. Do not mount the power supply to a plastic or other insulating surface. Ensure that the operating environment does not exceed 60°C.

Wire Connections -

SL45, L92, SL92, and SL93 AC Mains (White and Yellow) - The power supply may operate from 115VAC or 230VAC ($\pm 10\%$). The connection to the AC line is different depending on the input voltage. For the SL45, SL92, and L92, the yellow wire and either of the white wires may be connected to the 115VAC line. If operation from 230VAC line is required, please connect the two white wires to the AC power source. The remaining wire should always be insulated to prevent accidents. When using multiple power supplies in the same system, the unused wire should not be connected in parallel with other power supplies.

L88 AC Mains (Grey and Yellow) - The power supply may operate from 115VAC or 230VAC ($\pm 10\%$). The connection to the AC line is different depending on the input voltage. The two yellow wires may be connected to the 115VAC line. If operation from 230VAC line is required, please connect the grey wire and one of the yellow wires to the AC power source. The remaining wire should always be insulated to prevent accidents.

High Voltage (Thick Red and Black Wire) - Most power supplies are provided with an Alden Style connector (#8102-F). Power supplies with option "Z" were shipped with high voltage connectors. This connector is intended for application up to 10,000 Feet. Some customers prefer to install the connector and ballast resistor themselves. In this case, care should be taken as the start voltage of some power supplies can exceed 18,000 Volts. Connections should be properly insulated to prevent arcing and coronal discharge.

CDRH Delay (Violet Wire) - Power supplies with option "B", have a 1.5" violet wire loop. These power supplies will have a 3-5 second delay before the output is enabled. This delay can be disabled by cutting the violet loop. Although no harmful voltage is present when the wires are cut, they should be properly insulated to prevent accidents.

Ground (Green Wire) - Connect safety ground (i.e. A/C mains ground)

Tel: 501.407.0712
Fax: 501.407.0036

P. O. Box 191117
Little Rock, AR 72219-1117
sales@powertechnology.com
www.powertechnology.com

Adjustment -

Current Adjustment, internal (X option) - The X option allows for the output current to be adjusted $\pm 30\%$ from nominal point. Adjustment may be limited by the design and operating capability of the power supply.

Current Adjustment, internal (C option) - The C option allows a maximum adjustment range of $\pm 30\%$ from a nominal point. Adjustment may be limited by the design and operating capability of the power supply.

Control -

TTL Level Control (K Option) - With white/red wire connected to +5VDC, connect white/black wire to DC ground to turn the unit on. Open the connection to turn unit off. With proper interfacing, the power supply can be controlled by TTL circuitry. The K option control circuitry requires 10mA minimum to operate.

EMI Shielding

Electromagnetic Shielding (S Option) - A thin copper shielding can be installed around the power supply. This prevents unwanted electrical interference in sensitive applications. The shield is connected to the internal ground by a black wire.



Tel: 501.407.0712
Fax: 501.407.0036

P. O. Box 191117
Little Rock, AR 72219-1117
sales@powertechnology.com
www.powertechnology.com

L88 Reference Drawing:

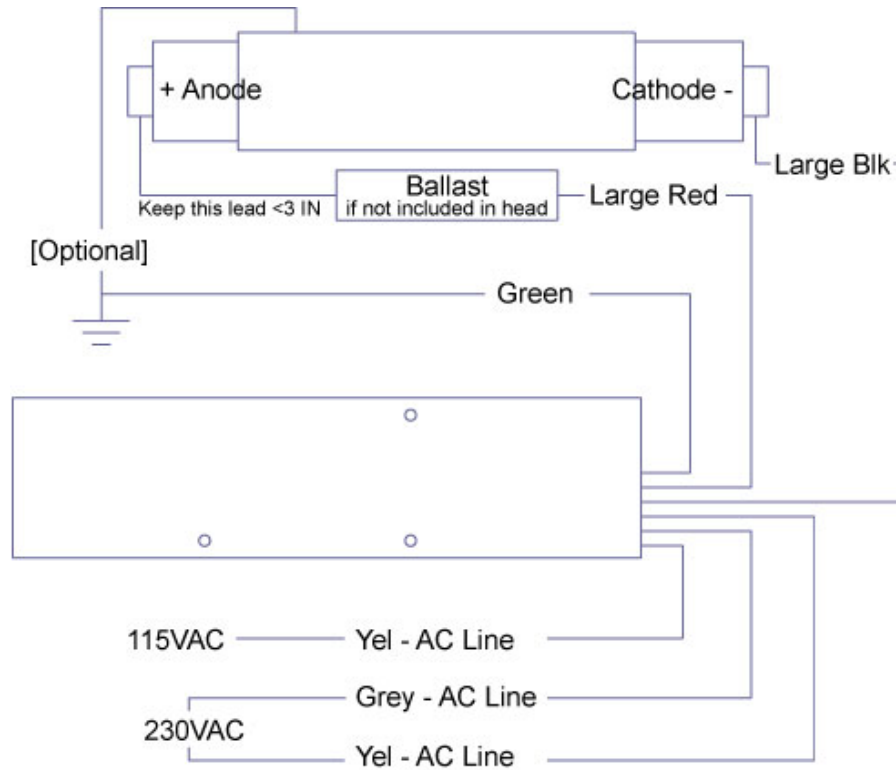

Tel: 501.407.0712
 Fax: 501.407.0036

P. O. Box 191117
 Little Rock, AR 72219-1117
 sales@powertechnology.com
 www.powertechnology.com

SL92 & L92 Reference Drawing:

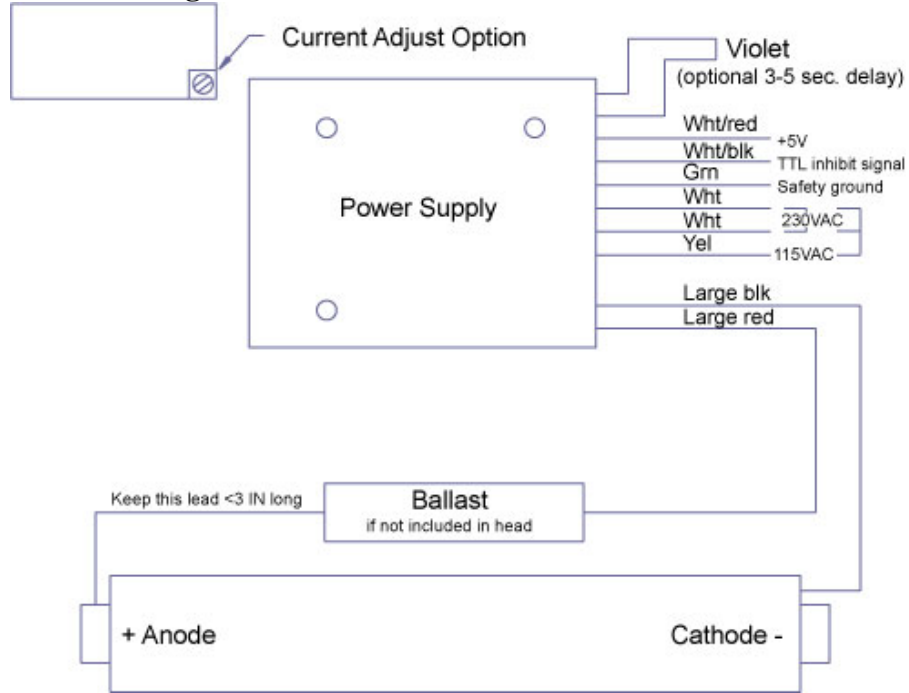

SL45 and SL93 Reference Drawing:

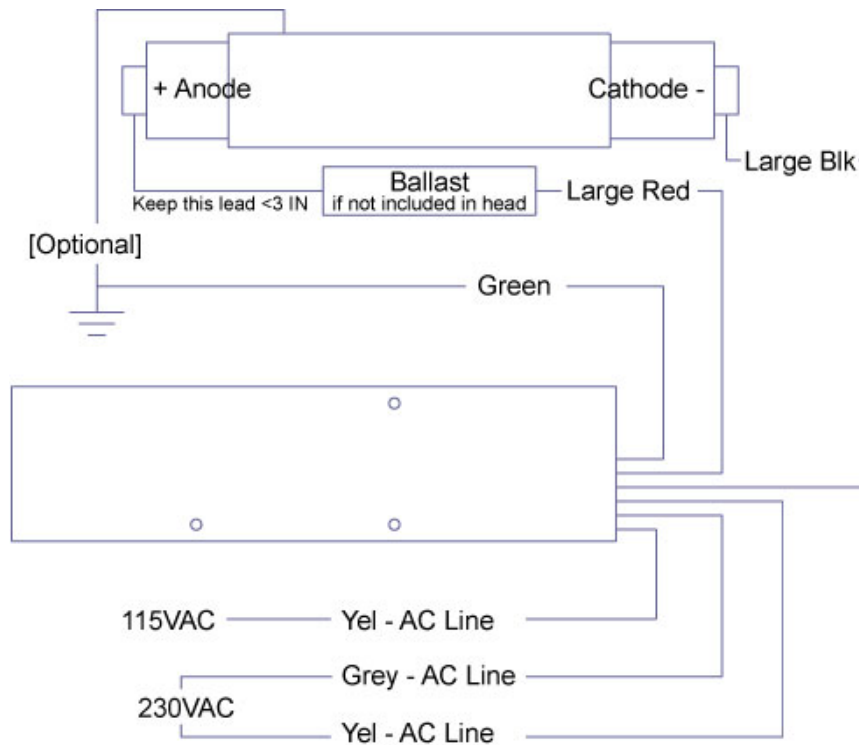

Tel: 501.407.0712
Fax: 501.407.0036

P. O. Box 191117
Little Rock, AR 72219-1117
sales@powertechnology.com
www.powertechnology.com