

m2k-BA-1870-0700-SE

High Power GaSb based MIR Laser

m2k Laser

High-Brightness Diode-Lasers

General Description

The m2k-BA-1870-1000-SE is a mid-infrared diode laser which is used in medical applications, illumination, materials processing or pumping of mid-infrared solid-state and disc lasers. The broad-area, gain-guided lasers are based on the (AlGaIn)(AsSb) material system, epitaxially grown on GaSb substrates. The single emitters are mounted onto c-mounts and feature output powers up to 1000 mW. The fast axis beam divergence is as low as 44° FWHM due to an innovative waveguide design.

Output power:	700 mW
Wavelength:	1870 nm
Divergence:	44° (FWHM)
Emitter width:	90 µm
Packaging:	C-Mount

Advantages

- high brightness
- nominal output of 700 mW
- emitter stripe width of 90 µm
- divergence in the fast direction of 44° (FWHM)
- highly reliable
- compact package
- passive cooling
- customized packaging possible

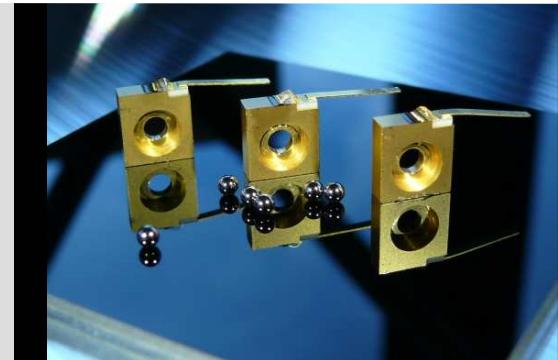

Related products

- Single emitter with 150µm stripe width (BA-1870-1000-SE)
- Fiber coupled single emitter module for 200µm core fiber with NA=0.22 (BA-1870-E0500-MMF200)
- Laser bar with 20% or 30% fill factor (BA-1870-20-10-BAR, BA-1870-30-10-BAR)
- Fiber coupled bar modules (BA-1870-B06-MMF600, BA-1870-B12-MMF600, BA-1870-B18-MMF600)

C-Mount

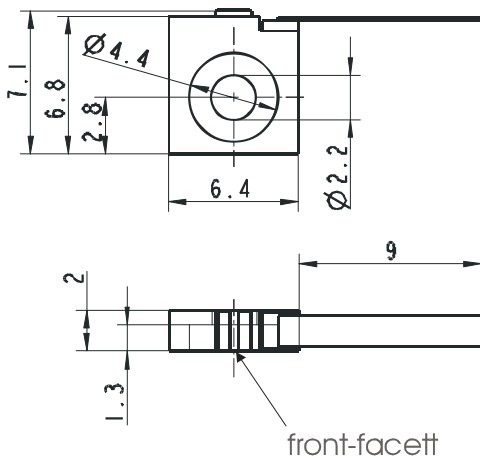

DHP Mount

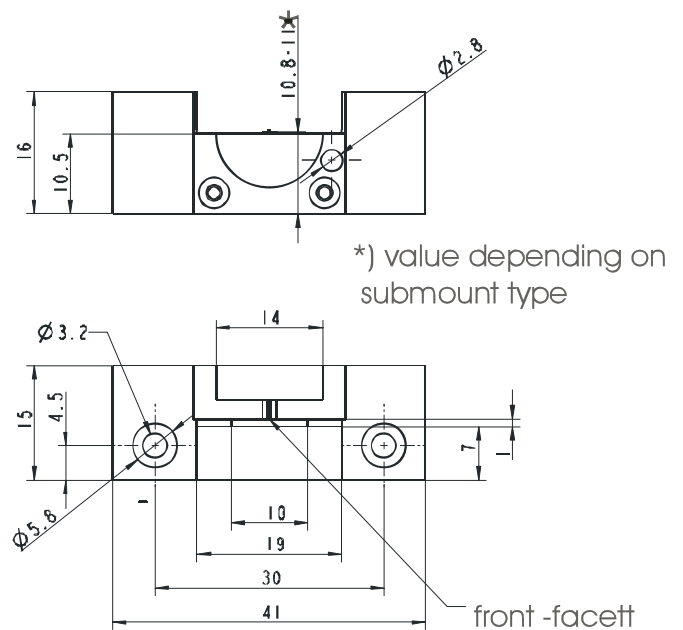

m2k-laser GmbH
Tullastrasse 72
D-79108 Freiburg

Fon: +49 (0) 761 5158-7370
Fax: +49 (0) 761 5158-7376

Email: info@m2k-laser.de
Internet: www.m2k-laser.de

m2k-BA-1870-0700-SE

Specification Data

Product		BA-1870-0700-SE
Optical data		
CW - nominal output-power	mW	700
Center wavelength ¹	nm	1870
Center wavelength variation (@ 20 °C) ²	nm	± 20
Spectral bandwidth (FWHM)	nm	< 5
Divergence parallel (FWHM)	°	< 11
Divergence perpendicular (FWHM)	°	< 47
Design data		
Stripe width	µm	90
Cavity length	µm	1500
Emitter height	µm	100 .. 110
Electrical data		
Typical operation current	A	2.4
Maximum operation current	A	2.7
Typical threshold current	A	0.35
Typical slope efficiency	W/A	> 0.29
Operation voltage	V	< 1.5
Thermal data		
Operating temperature	°C	15 ... 30
Recommended heat sink temperature	°C	20
Storage temperature ³	°C	-20 ... +60
Operating conditions	non-condensing atmosphere	
Other specifications		
Heat sink type	c-mount	
Cathode (-)	wire flag	
Anode (+)	base plate	
RoHS 2002/95EC compliant	yes	

Related products

BA-1870-E0500-MMF200		
CW - nominal output-power	mW	500
Fiber core	µm	200
NA		0.22

¹ Other wavelength on request

² Smaller spectral bandwidth on request

³ in a non condensing atmosphere

Safety

This is a laser class IV product according to IEC - Standard International Commission (Publication 825, 1993). The laser light emitted from this laser diode is invisible and/or visible and is harmful to the human eye. The safety regulations for eye and personell protection included in the IEC Standard must be observed to avoid any harm to operating personell. Avoid direct exposure and looking into the laser diode, into the collimated beam or into the fiber when it is linked to the module.

Storage and shipping

Store and ship the diode laser with shortened electrical contacts, in a clean and dry atmosphere and in a tempertaure range of 0°C to 60°C.

Operation and handling

Diode lasers are extremely sensitive to over-voltage. Take extreme precaution to avoid electrostatic charges. Precautions against spiking during switching on and off the power supply must be assured. Correct polarity of power supply must be assured. During handling personell has to wear wrist straps. Grounded work surfaces and additional antistatic techniques are mandatory during handling.

Device failure and safety hazard are caused by operation in excess of maximum ratings. Exceeding output power and temperature specification will result in accelerated device ageing.

Do not mount via any paste-like media!

